

TOPCAT[®]
HIGH-END EFFECTS

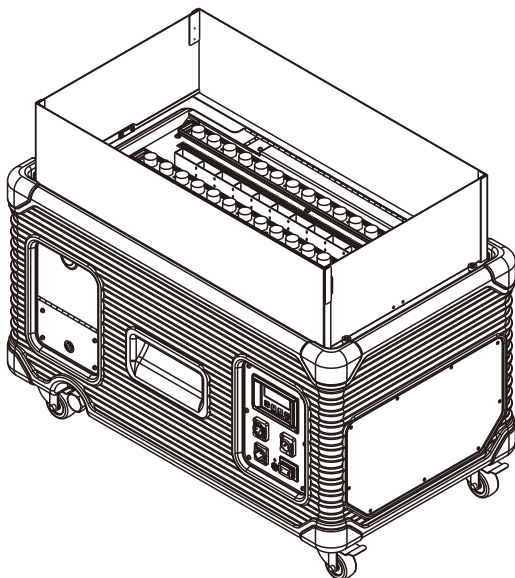

H-SF800
WATER MIST FLAMER

USER MANUAL

1 BEFORE YOU BEGIN

1.1 What Is Included



- H-SF800 Machine
- Power Cord
- Water Hose
- Warranty card
- User Manual

1.2 Unpacking Instructions

Carefully unpack the product immediately and check the container to make sure all the parts are in the package and are in good condition.

If the box or the contents (the product and included accessories) appear damaged from shipping, or show signs of mishandling, notify the carrier or dealer/seller immediately. In addition, keep the box and contents for inspection.

1.3 Symbols

Symbol	Meaning
	Caution Critical installation, configuration, or operation information. Not following these instructions may make the product not work, cause damage to the product, or cause harm to the operator.
	Important Important installation or configuration information. Failure to comply with this information may keep the product from working correctly.
	Information Useful information.

1.4 Disclaimer

The information and specifications contained in this User Manual are subject to change without notice. DJPOWER assumes no responsibility or liability for any errors or omissions and reserves the right to revise or to create this manual at any time.

Copyright © 2022 DJPOWER. All rights reserved.

1.5 Safety Notes

Please read the following Safety Notes carefully before working with the product. The notes include important safety information about installation, usage, and maintenance.

1.5.1 Personal Safety

- Always connect the product to a grounded circuit to avoid the risk of electrocution.

- Make sure that children, unauthorized people and animals do not obtain access to the machine.
- Eye protection is always required when operate the machine closely.

1.5.2 Personal Safety

- For safety reasons, we do not recommend mounting the product in any capacity. Operate the product while it is on the ground only, don't tilt.
- The product is for indoor use only! To prevent risk of fire or shock, do not expose the product to rain or moisture.
- CAUTION: When transferring product from extreme temperature environments, (e.g. cold truck to warm humid ballroom) condensation may form on the internal electronics of the product. To avoid causing a failure, allow product to fully acclimate to the surrounding environment before connecting it to power.

1.5.3 Power and Wiring

- Always make sure that the voltage of the outlet to which you are connecting the product is within the range stated on the decal or rear panel of the product.
- Make sure the power cord is not crimped or damaged.
- Never connect this product to a dimmer pack or rheostat.
- Never disconnect the product from power cord by pulling or tugging on the cord.
- To eliminate unnecessary wear and improve its lifespan, during periods of non-use completely disconnect the product from power via breaker or by unplugging it.

1.5.4 Operation

- Do not operate this product if you see damage to the housing or cables. Have the damaged parts replaced by an authorized technician at once.
- Never carry the product by the power cord or any moving part. Always use the handles.
- Drain the tank before transporting the product.
- The maximum ambient temperature (T_a) is 104 °F (40 °C). Do not operate the product at higher temperatures.
- Always disconnect the product from the power source before cleaning.
- This product contains no user-serviceable parts. Any reference to servicing in this User Manual will only apply to properly trained, certified technicians. Do not open the housing or attempt any repairs which can lead to damage or malfunction.
- In the event of a serious operating problem, stop using the product immediately.
- To reach better effect, clean water tank regularly when not use the machine.



Please save this manual for future use. Sell the machine again, be sure to attach the instructions.

2 INTRODUCTION

2.1 Description

In order to solve the limitation that real fire cannot be used in some occasions, DJPOWER has developed the H-SF800 Water Mist Flamer . IP55 level, and can be used normally in rainy. It is a device that uses the principle of ultrasonic water mist mixing. With 64 LEDs, which can simulate a realistic flame effect. High-strength composite material integrated chassis, durable and rust-free. Automatic refill function of tap water pipeline. With water storage tank, easy to use. It is suitable for various occasions that need to create a fiery atmosphere indoors and outdoors.

2.2 Description

- The flame effect of height and luminance is adjustable
- The rainproof structure design of the whole machine, IP55 waterproof grade
- Integrated in a plastic case (with castors) and folded light barrier, applicable for touring,
- 64PCS 3W LED
- Automatic refill function of tap water pipeline;
- With water storage tank, easy to use.
- Drain holes design for water tank, free from leakage;
- Anti-loose power plug;
- Built in LCD control and DMX control.

2.3 Product Overview

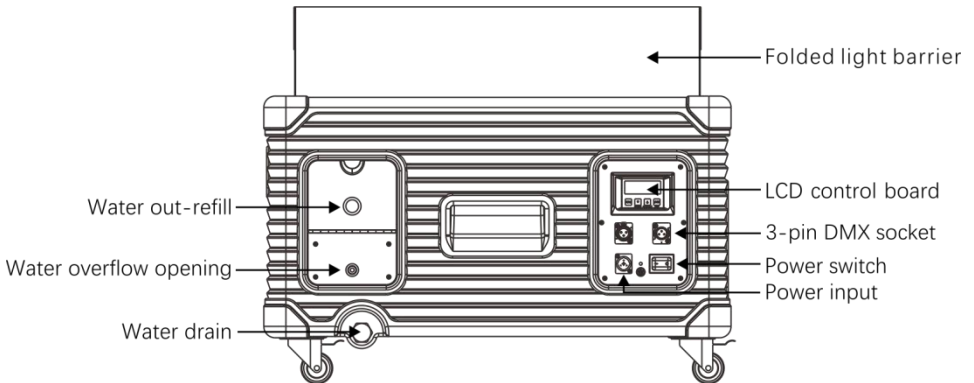

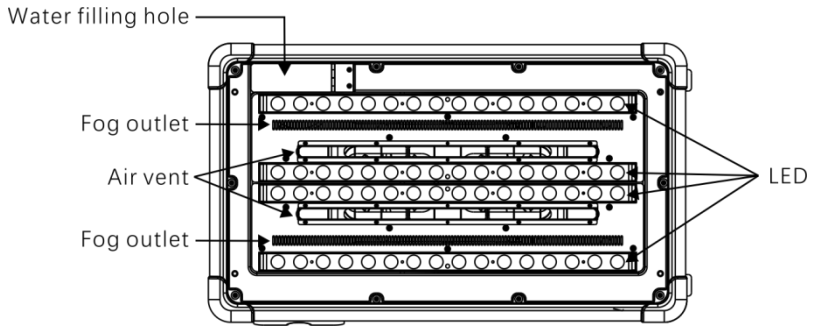

2.4 Product Dimensions

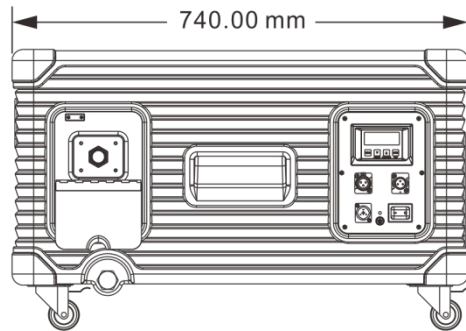
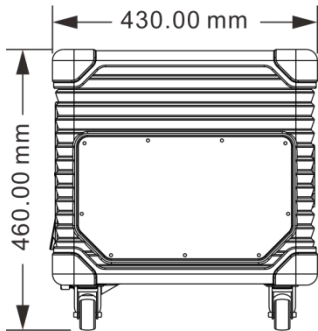
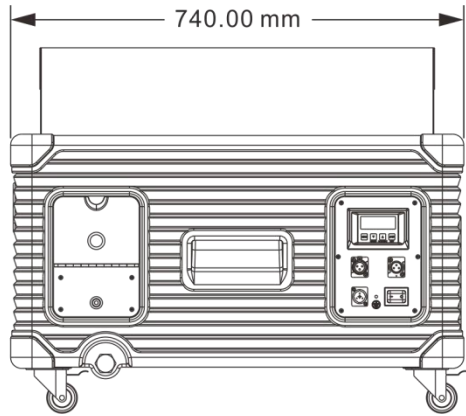
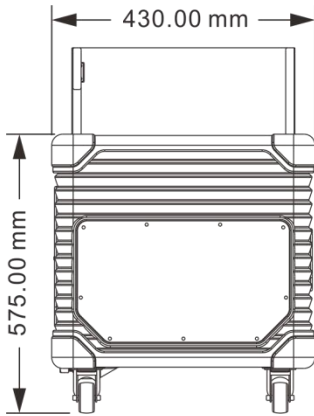

3 TECHNICAL SPECIFICATION

Voltage	Input Voltage & Rate	AC 220-240 V, 50/60 Hz
	Total Power Consumption	800 W
Light	Power Consumption of each LED	3 W
	Total LED Quantity	64 pcs
	Total LED Power	192 W
Atomizer	Total Power Consumption	600 W
	Unit Quantity	2 pcs
	Power Consumption of each Unit	300 W
IP Rate	IP Rate	IP 55
Capacity	Main Water Tank Capacity	Appr. 14 L
	Adjustable Water	Appr. 3.5 L
	Upper Water Tank Capacity	Appr. 9 L
Output	Adjustable Flame Concentration	high/ low
	Adjustable Flame Volume	1-100
	Adjustable Flame Luminance	OFF, 1-100 close
	Adjustable Height	1-11
	Continuous Output	√
	Max Continuous Output Duration	Appr. 210 min
Control	On-device Manual Control	LCD control board
	Wireless Control	×
	Wired Control	×
	Control Protocol	DMX-512/RDM
	DMX Channel Range	4
Accessory	Folded light barrier	√
	Water hose	√
Weight & Dimension	Net Weight	35 kg
	Gross Weight	42.5 kg
	Machine Dimensions	740 × 430 × 575 mm (State of work)
		740 × 430 × 460 mm (State of packing)
Packing Dimensions	810 × 500 × 530 mm	
Consumable	Consumable	Water

4 SETUP

4.1 AC Power

The machine has two kinds of voltage power supply, it can work with an input voltage of AC 220 V-240 V, 50/60 Hz, depending on the specific model.

To determine the product's power requirements (circuit breaker, power outlet, and wiring), use the current value listed on the label affixed to the product's back panel, or refer to the product's specifications chart. The listed current rating indicates the product's average current draw under normal conditions.



Always connect the product to a protected circuit (circuit breaker or fuse). Make sure the product has an appropriate electrical ground to avoid the risk of electrocution or fire.



Never connect the product to a rheostat (variable resistor) or dimmer circuit, even if the rheostat or dimmer channel serves only as a 0 to 100% switch.

4.2 Power Plug

The Flame Machine H-SF800 comes with a power input cord terminated with a Lockable Powerkon connector on one end and an EU plug on the other end (EU & China market). If the power input cord that came with your product has no plug, or if you need the change the plug, use the table below to wire the new plug:

Connection	Wire (U.S.)	Wire (Europe)
AC Live	Black	Brown
AC Neutral	White	Blue
AC Ground	Green/Yellow	Green/Yellow

4.3 DMX Linking

You can link the H-SF800 to a DMX controller using a 3- or 5-pin DMX connection. If using other DMX-compatible products with this product, you can control each individually with a single DMX controller. Instructions for connecting and configuring this product for DMX operation are in the User Manual.

4.4 Mounting

Before mounting the product, read and follow the safety recommendations indicated in the Safety Notes.

4.4.1 Orientation

For safety reasons, we do not recommend mounting the product in any capacity. Operate the product while it is on the ground only, don't tilt, and make sure there is adequate room for ventilation, configuration, and maintenance.

4.4.2 Rigging

DJPOWER recommends using the following general guidelines when mounting this product.

- Before deciding on a location for the product, make sure there is easy access to the product for maintenance and programming purposes.

- Make sure that the structure or surface onto which you are mounting the product can support the product's weight (see the Technical Specifications).
- When mounting the product on the floor, make sure that the product and cables are away from people and vehicles.

5 OPERATION

5.1 Preparing for Operation

- After checking that all the parts are intact and complete, position the machine on flat.
- Add appropriate water to the machine.
- Connect the Neutrik power cord to the machine. Please make sure the required and provided electricity voltage and the electricity outlet is grounded.
- Turn on the machine.

5.2 On-device Control Panel

This LCD display is optional in Chinese and English, which is convenient for customers to operate.

The condition to meet this mode is: disconnect the DMX signal (when the DMX signal is connected, this control mode is invalid).

The LCD controller contains 4 buttons:

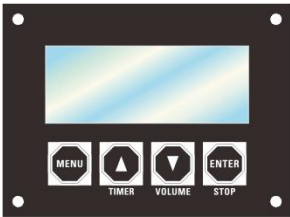

Button	Function
<MENU>	Menu pages choose
<▲>	Increase, also "TIME" button for fog output regularly
<▼>	Decrease, also "VOLUME" button for fog output
<ENTER>	In/out, also for "stop" button

5.2.1 Menu Map

	Display	Description	Parameter Range
Starting pages	Ready H-SFB00		
	Flame Concentration High	Flame Concentration Setting, press to set flame concentration	High/Low
Working Setting Pages	Flame Volume 100	Flame Volume Setting, press to set flame volume	1 ~ 100
<p>On any page, press the "ENTER" return to the first page In working state, press the "ENTER" to stop working and return to the first page After entering the page, press "▲" or "▼" to change the current setting</p>			

Display	Description	Parameter Range
On the first page, press the“TIMER” to enter the timing function, and the relevant pages instruction as follows:		
<div style="border: 1px solid black; padding: 5px; display: inline-block;"> Timer Interval 10s </div>	Press “▲” or “▼”to set timer interval of TIMER mode	5 ~ 600s
<div style="border: 1px solid black; padding: 5px; display: inline-block;"> Timer Duration 10s </div>	Press “▲” or “▼” to set timer duration of TIMER mode	5 ~ 300s
The above pages will be displayed cyclically, and the time (such as 10s) is based on the currently set value (the settings of the 1st and 2nd pages).		
<div style="border: 1px solid black; padding: 5px; display: inline-block;"> DMX address 512 </div>	DMX address setting	1~512
<div style="border: 1px solid black; padding: 5px; display: inline-block;"> RDM-UID 512D00020000 </div>	RDM-UID	
<div style="border: 1px solid black; padding: 5px; display: inline-block;"> Working mode Manual </div>	Working mode setting.Manual mode, the machine working as set parameter	Manual/ Auto
<div style="border: 1px solid black; padding: 5px; display: inline-block;"> Auto Run Last On </div>	The machine will automatically run previous setting when power on again	On/ Off
<div style="border: 1px solid black; padding: 5px; display: inline-block;"> Flame Luminance Off </div>	Flame luminance setting,press to set flame luminance	Off、1% ~ 100%;
<div style="border: 1px solid black; padding: 5px; display: inline-block;"> Flame Height 11 </div>	Flame height setting, press to set flame height	1-11
<div style="border: 1px solid black; padding: 5px; display: inline-block;"> Language English </div>	select the language and save by ENTER	Chinese/ English

5.3 DMX Mode & Operation

The Machine H-SF800 works with a DMX controller.

- Connect the product to a suitable power outlet.
- Turn the product on.
- Connect a DMX cable from the DMX output of the DMX controller to the DMX input socket on the product.

5.3.1 Starting Address

When selecting a starting DMX address, always consider the number of DMX channels. If you choose a starting address that is too high, you could restrict the access to some of the product’s channels.



DJPOWER® H-SF800 DMX set the starting address in the 001 - 512 DMX range and uses 4 DMX channels, which defines the highest configurable address to 508 to have all channels controllable.



Connect a DMX cable from the DMX output of the DMX controller to the DMX input socket on the product, or press repeatedly “MENU” button until the LCD shows “DMX Address”. Press “▲” or “▼” to set desired DMX starting address.

5.3.2 DMX Mode Menu Map

When connected with DMX controller and receive DMX signal, the display will always show current DMX starting address, that can be changed anytime by pressing “▲” or “▼”.



5.3.3 DMX Channel Assignments and Values

Channel	Function	Value	Description
1	Flame Volume	000 - 010	Close
		011 - 255	Bigger
2	Flame Concentration	000 - 010	Close
		011 - 128	Low
3	Flame Height	129 - 255	High
		000-010	Close
		011-021	First Gear
		022-045	Second Gear
		046-069	Third Gear
		070-093	Fourth Gear
		094-117	Fifth Gear
		118-141	Sixth Gear
		142-165	Seventh Gear
		166-189	Eighth Gear
		190-213	Ninth Gear
4	Flame Luminance	214-237	Tenth Gear
		238-255	Eleventh Gear
		000 - 010	Close
		011 - 255	Brighter

5.3.4 RDM Function

“RDM-UID” is the unique UID code of the machine

You can use RDM long-range revise DMX address code

5.4 Auto Run Last Settings

If the machine is shut off while it is operating at standalone mode (On-device & Wireless control), the "Auto Run Last Setting" will allow the machine to recover its previous same operating status when the unit is powered on again without pressing any button.



- **Shut off:** Get disconnected from power source, or turn off the power switch
- **Power on:** Get connected with power source, or turn on the power switch

6 TECHNICAL INFORMATION

6.1 LED Working Life

As the number of uses increases and time goes by, the brightness of the LED will gradually decrease. The denser LED design makes the operating temperature of the LED higher than that of a single LED. Using cluster LED at maximum intensity will reduce their lifetime. Under normal circumstances, the life of LED is 40,000-50,000 hours. Extending LED life can be achieved by improving ventilation around the product and reducing the surrounding temperature to the optimum operating range. In addition, limiting the overall projected intensity also helps to extend the lifetime of the LED

6.2 Maintenance

H-SF800 needs regular maintenance to achieve the best performance. In order to achieve the best results, some cleaning and maintenance steps are essential:

1. Cleaning the water tank after using machine, steps as follow:

- 1) Open the drain nut, cleaning the water tank
- 2) Install the drain nut, store machine well

2. Clean H-SF800 water tank regularly, steps as follow:

- 1) Open the drain nut, cleaning the water tank
- 2) Install the drain nut well
- 3) Fill in water through the manual water filling port until the water is full
- 4) Open the drain water nut again, cleaning the water tank
- 5) Operating the 3.4 step again
- 6) Install the drain nut well

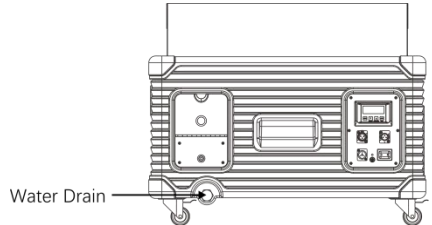

Manual Water Filling Port

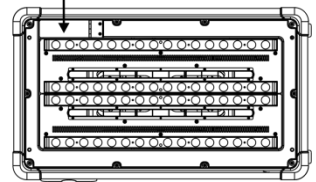

Test-run your DJPOWER® H-SF800 on a monthly basis to achieve the best performance.

6.3 Storage

6.3.1 Machine Storage

Before storing the machine, clean it as described in the cleaning procedure above

