

# TOPCAT<sup>®</sup>

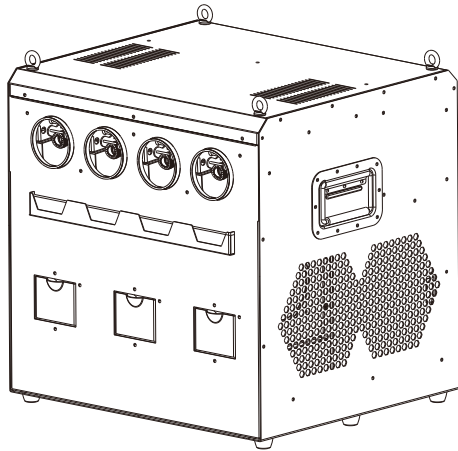

**WP-4 PRO BUBBLE FOG MACHINE**

---

**USE MANUAL**

# 1 BEFORE YOU BEGIN

## 1.1 What Is Included

- WP-4 Super Bubble Fogger × 1
- Power cord × 1
- Warranty card × 1



Optional accessory: Flightcase (Extra charge)

## 1.2 Unpacking Instructions

Carefully unpack the product immediately and check the container to make sure all the parts are in the package and are in good condition.

If the box or the contents (the product and included accessories) appear damaged from shipping, or show signs of mishandling, notify the carrier or dealer/seller immediately. In addition, keep the box and contents for inspection.

## 1.3 Symbols

Symbol	Meaning
	<b>Caution</b> Critical installation, configuration, or operation information. Not following these instructions may make the product not work, cause damage to the product, or cause harm to the operator.
	<b>Important</b> Important installation or configuration information. Failure to comply with this information may keep the product from working correctly.
	<b>Information</b> Useful information.

## 1.4 Disclaimer

The information and specifications contained in this User Manual are subject to change without notice. DJPOWER assumes no responsibility or liability for any errors or omissions and reserves the right to revise or to create this manual at any time.

Copyright © 2019 DJPOWER. All rights reserved.

## 1.5 Safety Notes

Please read the following Safety Notes carefully before working with the product. The notes include important safety information about installation, usage, and maintenance.

### **1.5.1 Personal Safety**

- Always connect the product to a grounded circuit to avoid the risk of electrocution.
- Make sure that children, unauthorized people and animals do not obtain access to the machine.

### **1.5.2 Mounting and Rigging**

- The product is for indoor use! To prevent risk of fire or shock, do not expose the product to rain or moisture.
- CAUTION: When transferring product from extreme temperature environments, (e.g. cold truck to warm humid ballroom) condensation may form on the internal electronics of the product. To avoid causing a failure, allow product to fully acclimate to the surrounding environment before connecting it to power.
- Do not mount the product on a flammable surface (linoleum, carpet, wood, paper, carton, plastic, etc.).
- Do not use in a confined space. Always install the product in a location with adequate ventilation, at least 20 in (50 cm) from adjacent surfaces.
- Be sure that no ventilation slots on the product's housing are blocked.
- when hanging, please use the safety cables to fix four safety loop on the top cover and two handles on side cover.

### **1.5.3 Power and Wiring**

- Always make sure that the voltage of the outlet to which you are connecting the product is within the range stated on the decal or rear panel of the product.
- Make sure the power cord is not crimped or damaged.
- Do not connect the machine to the dimming controller or rheostat.
- Never disconnect the product from power cord by pulling or tugging on the cord.
- To eliminate unnecessary wear and improve its lifespan, during periods of non-use completely disconnect the product from power via breaker or by unplugging it.

### **1.5.4 Installation Instructions**

- Do not operate this product if you see damage to the housing or cables. Have the damaged parts replaced by an authorized technician at once.
- Make sure there are no flammable materials close to this product while it is operating.
- Do not cover or plug the output nozzle during operation.
- Do not cover the ventilation slots when operating to avoid internal overheating.
- Wipe up spitted fluid immediately. Moisture – also fluid – can destroy the electric.
- Never carry the product by the power cord or any moving part. Always use the handles.
- Empty the storage bin before transporting the product.
- The maximum ambient temperature (Ta) is 104 °F (40 °C). Do not operate the product at higher temperatures.
- Drain the tank before transporting the product. Bubble fluid or the fog fluid tanks shall be used for the relevant fluid only.
- Always disconnect the product from the power source before cleaning.

- This product contains no user-serviceable parts. Any reference to servicing in this User Manual will only apply to properly trained, certified technicians. Do not open the housing or attempt any repairs which can lead to damage or malfunction.
- In the event of a serious operating problem, stop using the product immediately.
- Use only DJPOWER Consumable. Bubble fluid PRO-PW and fog fluid PRO-C are recommended.



**Please save this manual for future use. When resell the machine, be sure to attach the instructions.**

## 2 INTRODUCTION

### 2.1 Description

TOPCAT WP-4 is a newly launched professional bubble fog machine for big stages and event halls. The 4-nozzle design can help produce huge amount of bubbles with fog filled inside. Innovative patented Jet-design ensures fog being trapped inside bubbles, avoids too much fog dispersing in the air. The height and distance of the bubble fog can be adjusted through changing the air outlet angle. Bubble fluid is well stored and sealed in the tank without going bad even after long time to ensure high quality show.

### 2.2 Features

- Innovative Jet design, create massive amount of fog filled bubbles;
- Well-designed heating system releases the fog evenly and purely, no fluid dropping off;
- Innovative Jet design, create massive amount of fog filled bubbles;
- Three fans with adjustable angles make the fog bubble fly higher, further;
- Built-in LCD control, 3-pin and 5-pin DMX control, easy to use;
- Big size fluid tanks, long running time on full output;
- Please use DJPOWER special bubble fluid PRO-PW and fog fluid PRO-C.

Note: The actual effect may be affected by the using environment.

### 2.3 Product Overview

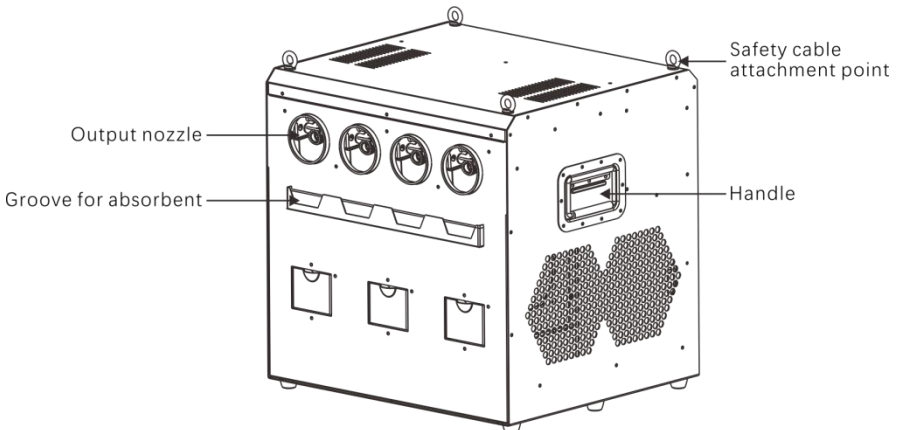

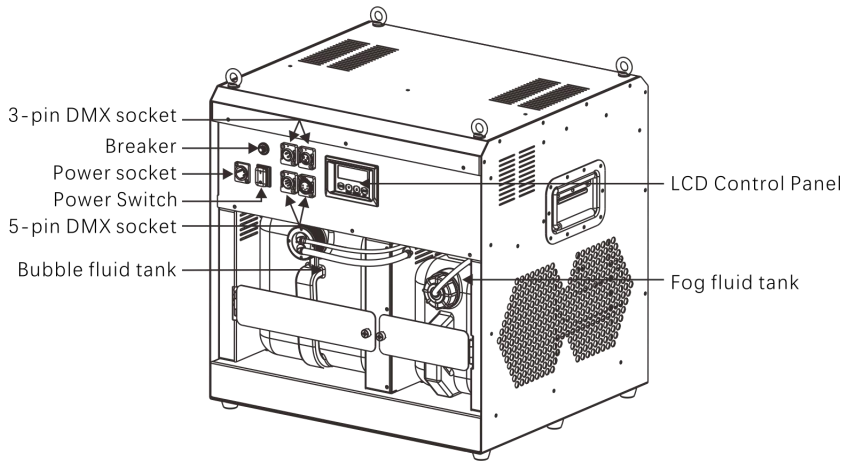

## 2.4 Product Dimensions

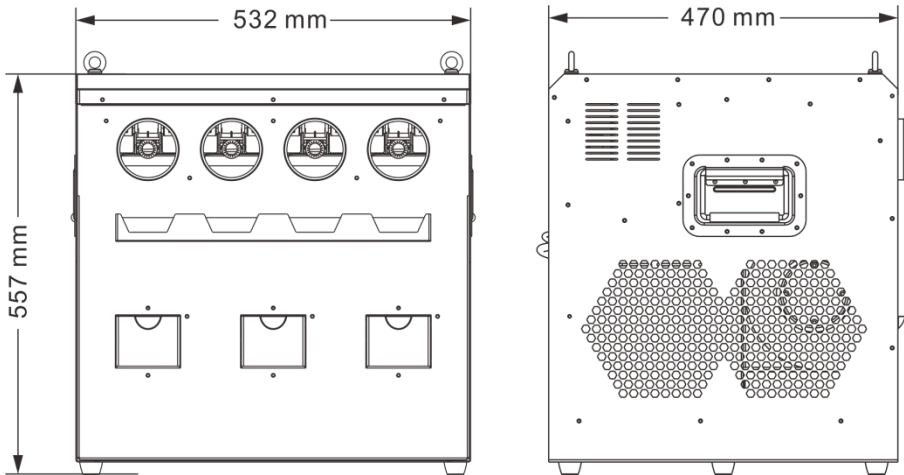

## 3 TECHNICAL SPECIFICATION

AC Power	Input Voltage & Rate	AC 220-240 V, 50/60 Hz; AC 110-120 V, 50/60 Hz
	Current Limiter Type	Breaker
	Current Limiter Specifications	8 A, 250 V

	Total Power Consumption	1,600 W
<b>Heating</b>	Heat Up Time	Appr. 3.5 min
<b>Capacity</b>	Bubble Fluid Tank Capacity	9 L
	Fog Fluid Tank Capacity	5 L
<b>Output</b>	Adjustable Output	√
	Max Fog Output Volume	Appr. 6,000 cuft/min
	Max Output Height	Appr. 10 m
	Max Output Distance	Appr. 10 m
	Fog Fluid Consumption (100% Output)	Appr. 90.9 min/L
	Bubble Fluid consumption (100% Output)	Appr. 12.5 min/L
	Consumable Type for Standard Output Test	PRO-PW and PRO-C and PRO-J
<b>Placement &amp; Mounting</b>	Horizontal	√
	Inclined	×
	Sidelong	×
	Hang Upside Down	×
	Rigging & Trussing	√
<b>Control</b>	On-device Manual Control	LCD control board
	Wireless Control	×
	Wired Control	×
	Control Protocol	DMX512
	DMX Channel Range	4
<b>Consumable</b>	Consumable	PRO-PW & PRO-C & PRO-J
<b>Weight &amp; Dimensions</b>	Net Weight	40 kg
	Gross Weight	50 kg
	Machine Dimensions	532 × 470 × 557 mm
	Packing Dimensions	730 × 590 × 640 mm

## 4 SETUP

### 4.1 AC Power

The machine has two kinds of voltage power supply, it can work with an input voltage of AC 110 V-120 V, 50/60 Hz or AC 220 V-240 V, 50/60 Hz, depending on the specific model.

To determine the product's power requirements (circuit breaker, power outlet, and wiring), use the current value listed on the label affixed to the product's back panel, or refer to the product's specifications chart. The listed current rating indicates the product's average current draw under normal conditions.



**Always connect the product to a protected circuit (circuit breaker or fuse). Make sure the product has an appropriate electrical ground to avoid the risk of electrocution or fire.**



**Never connect the product to a rheostat (variable resistor) or dimmer circuit, even if the rheostat or dimmer channel serves only as a 0 to 100% switch.**

## 4.2 AC Plug

The WP-4 Supper Bubble Fogger comes with a power input cord terminated with a Lockable power connector on one end. The other end is

- CN plug (CN market, etc.)
- EU plug (EU market, etc.)
- US plug (US market, etc.)

If the power input cord that came with your product has no plug, or if you need to change the plug, use the table below to wire the new plug:

Connection	Wire (U.S.)	Wire (Europe)
AC Live	Black	Brown
AC Neutral	White	Blue
AC Ground	Green/Yellow	Green/Yellow

## 4.3 Reset Breaker

- The unit is equipped with a resettable breaker. If the breaker trips, the unit will be disconnected from the power.
- Disconnect the machine from the power.
- Wait for about 15 minutes till the unit cools down.
- After that, manually press the button of the breaker to reset it.
- Reconnect the machine to the power outlet and continue to use it as recommended.

## 4.4 DMX Linking

You can link the X-7M to a DMX controller using a 3- or 5-pin DMX connection. If using other DMX-compatible products with this product, you can control each individually with a single DMX controller. Instructions for connecting and configuring this product for DMX operation are in the User Manual.

## 4.5 Mounting

Before mounting the product, read and follow the safety recommendations indicated in the Safety Notes.

### 4.5.1 Orientation

For safety reasons, make sure the unit is well mounted through bracket and with safety cable. Also make sure there is adequate room for ventilation, configuration, and maintenance.



**Do not mix bubble fluid and fog fluid.**

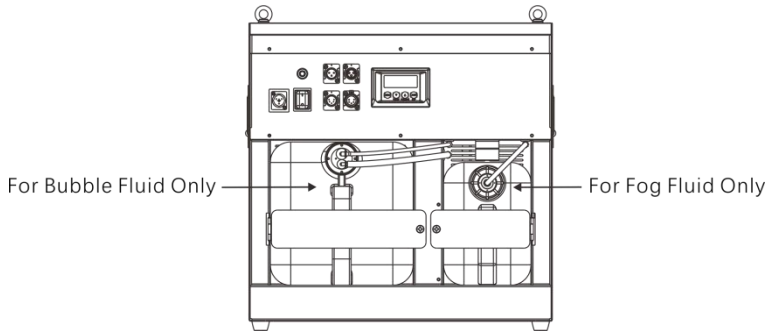

### 4.5.2 Rigging

Using the following general guidelines when mounting this product:

- Before deciding on a location for the product, make sure there is easy access to the product for maintenance and programming purposes.
- Make sure that the structure or surface onto which you are mounting the product can support the product's weight (see the Technical Specifications).
- When mounting the product on the floor, make sure that the product and cables are away from people and vehicles.

## 5 OPERATION

### 5.1 Preparing for Operation

- After checking that all the parts are intact and complete, position the machine on flat.
- Withdraw the fluid tank from its compartment and remove its cap. Add bubble fluid and fog fluid to the specified tank.
- Verify that the plastic hoses attached to the cap are in place and in good condition without bending or warp.
- Always connect the product to a grounded circuit. Before power on, make sure it is connected with the rated voltage.
- Turn on the machine, and " Warming up" shows on the display during the heating-up process. After approx. 3 minutes, the display changes to "Ready to work" when the machine finishes heating.



## 5.2 On-device Control Mode & Operation

To access the control panel functions, use the four buttons located underneath the LCD display.

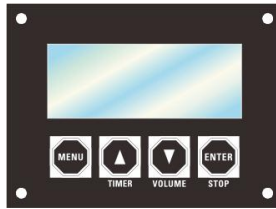

Button	Function
<MENU>	Switch menu pages to select a function
▲ <TIMER>	Increases the numeric value of current function Trigger TMER output mode
▼ <VOLUME>	Decreases the numeric value of current function Trigger Manual output mode
<ENTER> <STOP>	Save settings STOP turns the fog output off

### 5.2.1 Menu Map

	Display	Description	Parameter Range
Standby page	Warming Up >>>>>>>>>>	The unit is heating.	
	Ready To Work TOPCAT WP-4	After about 3 minutes heating, it will show this page. That means the fog system finishes heating, and the unit is ready to emit haze.	
Setting Pages	Interval Set 10S	Press ▲ and ▼ button to set interval under TIMER mode.	5-200s
	Duration Set 10S	Press ▲ and ▼ button to set duration under TIMER mode.	5-200s
	Bubble Output ON	Press ▲ and ▼ button to set bubble output.	ON/OFF
	Haze Output 100%	Press ▲ and ▼ button to set haze output.	1%-100%/OFF



	Fan Speed 100%	Press ▲ and ▼ button to set fan speed.	1%-100%/OFF
	DMX512 Address 1	Press ▲ and ▼ button to set DMX starting address.	1 - 512
	Clean Mode OFF	Press <b>UP</b> or <b>DOWN</b> to set cleaning mode ON/OFF. (When cleaning mode is ON, it will override all the other functions. Default cleaning time is 1 minute without turning of the mode manually.)	ON/OFF
<b>Working Status Page</b>	Working TOPCAT WP-4	This is the page shows when the unit is working.	

### 5.3 DMX Mode & Operation

WP-4 Super Bubble Fogger works with a DMX controller.

- Connect the product to a suitable power outlet.
- Turn the product on.
- Connect a DMX cable from the DMX output of the DMX controller to the DMX input socket on the product.

#### 5.3.1 DMX Working Page

	DMX Address 1	<b>Pressing “▲”or “▼” to set the DMX starting address</b>	1 - 512
<b>Standby and setup page</b>		When setting the DMX starting address, the number of channels occupied by the DMX mode must be considered. If the starting address is too high, some channels may not be controlled.	
		In DMX mode, each machine responds to the control of the DMX controller through its own unique starting address. Machines with the same starting address will be synchronized accordingly.	
		When connected with DMX controller and receiving DMX signal, the LCD display will always show current DMX starting address which can be reset by pressing “▲”or “▼”.	

#### 5.3.2 DMX Channel Assignments and Values

WP-4 Super Bubble Fogger has 4 DMX channels and can be connected by 3-pin or 5-pin DMX sockets. Set the DMX start address within the range of 001-512, you can independently control 512pcs devices with one DMX channel.

Channel	Function	Value	Description
1	Bubble Output	0-10	OFF
		11-255	ON
2	Fog Output	0-10	OFF
		11-255	Fog volume, low to high
3	Wind Output	0-10	OFF
		11-255	Fan speed, low to high
4	Bubble cleaning mode	0-10	OFF
		11-255	When Bubble cleaning mode is ON, overriding other functions

## 6 TECHNICAL INFORMATION

### 6.1 Maintenance

After each time use of the bubble fog machine, it is necessary to clean the fog head with clean water in time to prevent the residual bubble liquid on the fog head from solidifying and gluing, which will cause it to fail to be used normally next time!

Do not allow the WP-4 to become clogged due to the sticky bubble fluid. Cleaning and maintenance are necessary.

The recommended cleaning procedure is as follows.

- 1) Unplug the product from power.
- 2) Empty bubble fluid from the machine.
- 3) Add water to the bubble fluid tank.
- 4) Connect the product to power and allow it to warm up. Run the Cleaning Mode through Menu or DMX. Thoroughly rinse the Bubble fluid reservoir and fluid tube.
- 5) Run the product in a well-ventilated area. Do not allow the pump to run dry.
- 6) Excessive dust, fluid residue and dirt will degrade performance and cause overheating. Remove dust from air vents with air compressor, vacuum or soft brush. The casing could be cleaned by the damp cloth.
- 7) Restore the hoses and cap. Store the unit until next use.

Note: The default cleaning time is 1 minute. Without turning of the cleaning mode manually, it will shut of automatically after 1 minute.



Test-run your TOPCAT® WP-4 on a monthly basis to achieve the best performance.

### 6.2 Storage

Before storing the machine, clean it and empty the fluid tank.

