

**TOPCAT**<sup>®</sup>  
HIGH-END EFFECTS

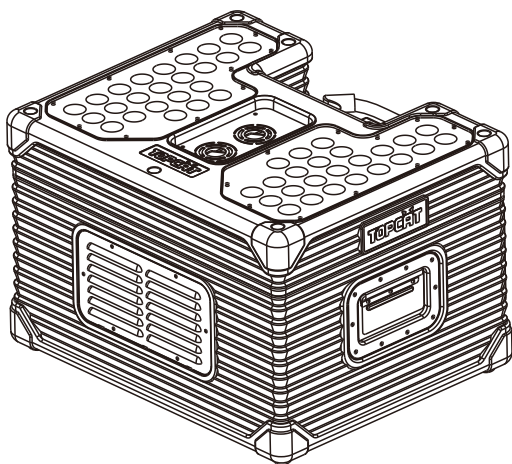

## **H-22V HURRICANE SUPER JET**

---

### **USER MANUAL**

GUANGZHOU DJPOWER ELECTRONIC TECHNOLOGY CO.,LTD



# 1 BEFORE YOU BEGIN

## 1.1 What Is Included

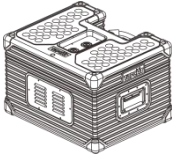

H-22V × 1

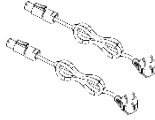

Power Cord × 2



Warranty Card × 1

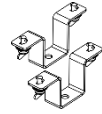



Omega bracket × 2

## 1.2 Unpacking Instructions

Carefully unpack the product immediately and check the container to make sure all the parts are in the package and are in good condition.

If the box or the contents (the product and included accessories) appear damaged from shipping, or show signs of mishandling, notify the carrier or dealer/seller immediately. In addition, keep the box and contents for inspection.

## 1.3 Symbols

Symbol	Meaning
<b>Caution</b>	
	Critical installation, configuration, or operation information. Not following these instructions may make the product not work, cause damage to the product, or cause harm to the operator.
<b>Important</b>	
	Important installation or configuration information. Failure to comply with this information may keep the product from working correctly.
<b>Information</b>	
	Useful information.

## 1.4 Disclaimer

The information and specifications contained in this User Manual are subject to change without notice. DJPOWER assumes no responsibility or liability for any errors or omissions and reserves the right to revise or to create this manual at any time.

Copyright © 2023 DJPOWER. All rights reserved.

## 1.5 Safety Notes

Please read the following Safety Notes carefully before working with the product. The notes include important safety information about installation, usage, and maintenance.

### 1.5.1 Personal Safety

- Always connect the product to a grounded circuit to avoid the risk of electrocution.
- During heating up and operation, the housing will be scalding hot. Do not touch.
- **The product is very hot during operation and it remains hot for a long time after operation has stopped. Do not touch the product's nozzle. Keep a distance of 100cm between nozzle and person.**
- **Make sure that children, unauthorised people and animals do not obtain access to the machine.**
- **Avoid direct eye exposure to the light source while the product is on.**

### 1.5.2 Mounting and Rigging

- This machine is designed for outdoor events and waterproof rate is IP53. But please don't immerse the machine in water.
- CAUTION: When transferring product from extreme temperature environments, (e.g. cold truck to warm humid ballroom) condensation may form on the internal electronics of the product. To avoid causing a failure, allow product to fully acclimate to the surrounding environment before connecting it to power.
- Do not mount the product on a flammable surface (linoleum, carpet, wood, paper, carton, plastic, etc.).
- Do not use in a confined space. Always install the product in a location with adequate ventilation, at least 20 in (50 cm) from adjacent surfaces.
- When hanging this product, always secure to a fastening device using a safety cable.
- Be sure that no ventilation slots on the product's housing are blocked or clogged by dust. If necessary, remove the dust.

### 1.5.3 Power and Wiring

- Always make sure that the voltage of the outlet to which you are connecting the product is within the range stated on the decal or rear panel of the product.
- Make sure the power cord is not crimped or damaged.
- Never connect this product to a dimmer pack or rheostat.
- Never disconnect the product from power cord by pulling or tugging on the cord.
- To eliminate unnecessary wear and improve its lifespan, during periods of non-use completely disconnect the product from power via breaker or by unplugging it

### 1.5.4 Operation

- Do not operate this product if you see damage to the housing or cables. Have the damaged parts replaced by an authorized technician at once.
- Do not use the product as a space heater.
- The maximum ambient temperature (Ta) is 104 °F (40 °C). Do not operate the product at higher temperatures.
- **Do not cover the ventilation slots when operating to avoid internal overheating.**
- **Do not cover or plug the output nozzle during operation.**

- Wipe up spitted fluid immediately. Moisture – also fluid – can destroy the electric.
- You may hear a loud popping sound during operation. This is normal.
- Never carry the product by the power cord or any moving part. Always use the handles of the machine.
- **Drain the tank before transporting the product.**
- Always disconnect the product from the power source before cleaning.
- In the event of a serious operating problem, stop using the product immediately.
- This product contains no user-serviceable parts. Any reference to servicing in this User Manual will only apply to properly trained, certified technicians. Do not open the housing or attempt any repairs which can lead to damage or malfunction.
- **Use only DJPOWER Consumable, fog fluid PRO-V is recommended.**



**Keep this User Manual for future use. If you sell the product, be sure that the purchaser receives this document.**

## 2 INTRODUCTION

### 2.1 Description

H-22V is a new rainproof high-speed dual nozzle super jet launched by DJPOWER.

It is specially designed for outdoor use and powerful fog output up to 20 meters.

With "Super-Jet" (Patent number: ZL201520934500.2) and "Immediate-stop" (Patent number: ZL201320700998.7) patent technology, the output speed and strength can be comparable with CO2 jet.

The housing is made of high-strength integrated composite materials, which is rust-free, strong and durable. The IP grade is IP53. It is suitable for outdoor performances, big bars, cultural tourism projects and other activities.

### 2.2 Features

- High-strength integrated composite housing
- Rainproof structural design. Rainproof grade is IP53
- Patent "Super-Jet", the much faster output speed
- "Immediate-stop" patent technology, fog reaction freely.
- With 48pcs 6W RGB LED, produce colorful fog columns.
- Dual output creates huge fog column up to 20 meters
- Advanced No-Fluid protection
- Anti-loose power plug
- Built-in LCD control and DMX512/RDM control
- Please use DJPOWER professional quick dissipating fog fluid PRO-V

## 2.3 Product Overview

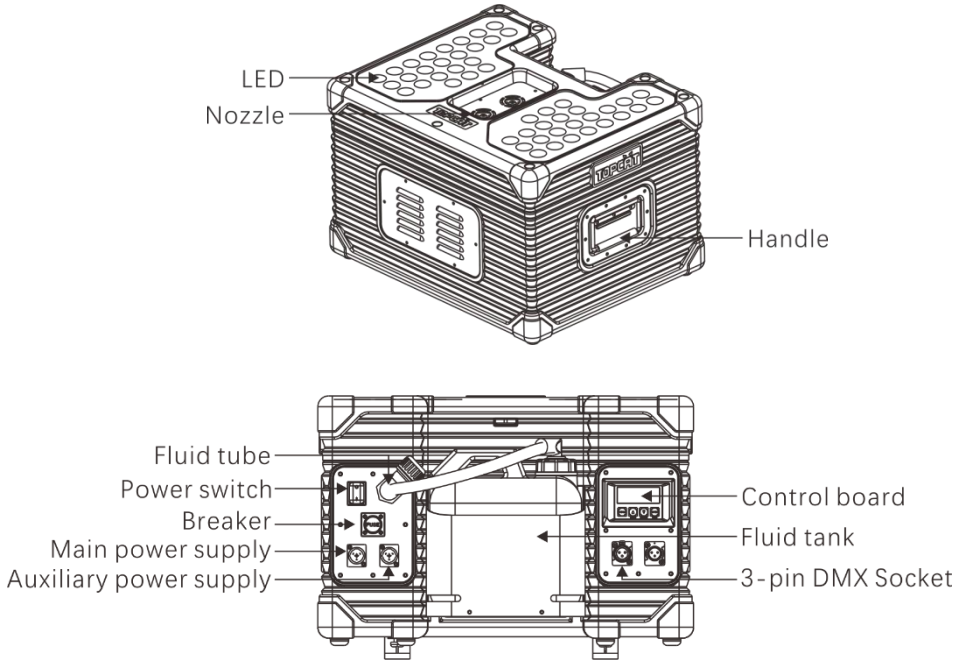

## 2.4 Product Dimensions

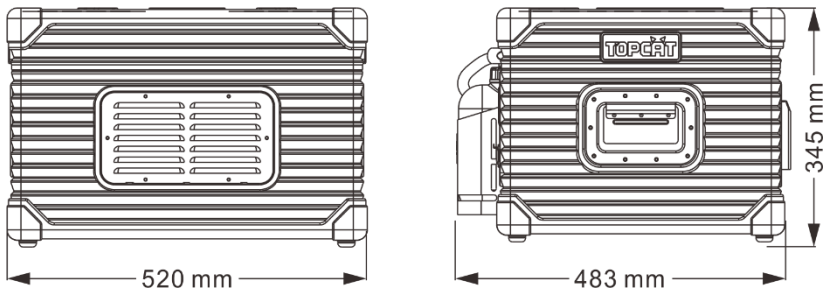

## 3 TECHNICAL SPECIFICATIONS

	Input Voltage & Rate	AC 100-120V, 50/60Hz	AC 220-240 V, 50/60 Hz
<b>AC Power</b>	Current Limiter Type	25A/250V	15A/250V
	Total Power Consumption	2,700W	3,500 W
<b>Heating</b>	Heat Up Time	Appr. 35 min	Appr. 25 min
	<b>Light Source</b>	LED color	RGB

	Total Power of LED	6 W × 48 pcs
<b>Tank</b>	Fluid tank	5 L
	Output adjustable	×
	Max Output Volume	Appr. 276,000 cuft/min
	Max Output Height	Appr. 20 m
<b>Output</b>	Fluid Consumption (100% Output)	Appr. 0.72 min/L
	Maximum Continuous Duration (100% Output)	Appr. 7 S
	Continuous Output	×
	Output Duration with Fluid Tank Full	Appr. 3.6 min
	Consumable	PRO-V
<b>Placement &amp; Mounting</b>	Horizontal (Place it on the ground without covering the heat dissipation holes.)	√
	Inclined	×
	side lay	×
	Hang Upside Down	√
	Rigging & Trussing	√
<b>Control</b>	On-device Manual Control	LCD control board
	Wireless Control	×
	Wired Control	×
	Control Protocol	DMX512/RDM
	DMX Channel Range	9
<b>Certification</b>	CE	√
	RoHS	√
<b>Consumable</b>	Consumable	PRO-V
<b>Weight &amp; Dimensions</b>	N.W.	46.5 kg
	G.W.	54.8 kg
	Machine Dimensions	520 × 483 × 345 mm
	Packing Dimensions	665 × 630 × 480 mm

## 4 SETUP

### 4.1 AC Power

The machine has a fixed voltage power supply and can work with an input voltage of AC 100V-120V, 50/60Hz or AC 220V-240V, 50/60Hz, depending on the specific model.

To determine the product's power requirements (circuit breaker, power outlet, and wiring), use the current value listed on the label affixed to the product's back panel, or refer to the product's specifications chart. The listed current rating indicates the product's average current draw under normal conditions.



**Always connect the product to a protected circuit (circuit breaker or fuse). Make sure the product has an appropriate electrical ground to avoid the risk of electrocution or fire.**



**Never connect the product to a rheostat (variable resistor) or dimmer circuit, even if the rheostat or dimmer channel serves only as a 0 to 100% switch.**

## 4.2 AC Plug

The H-22V comes with a power input cord terminated with a Lockable Powercon connector on one end and an EU plug on the other end (EU & China market). If the power input cord that came with your product has no plug, or if you need to change the plug, use the table below to wire the new plug:

Connection	Wire (U.S.)	Wire (Europe)
AC Live	Black	Brown
AC Neutral	White	Blue
AC Ground	Green/Yellow	Green/Yellow

## 4.3 DMX Linking

You can link the H-22V to a DMX controller using a 3-pin DMX connection. If using other DMX-compatible products with this product, you can control each individually with a single DMX controller. Instructions for connecting and configuring this product for DMX operation are in the User Manual.

## 4.4 Mounting

Before mounting the product, read and follow the safety recommendations indicated in the Safety Notes.

### 4.4.1 Orientation

Always mount this product in a safe position and make sure there is adequate room for ventilation, configuration, and maintenance. The H-22V should be suspended upright or upside down using the 2 Omega brackets included, or it can be placed on its rubber feet on a flat level surface.

### 4.4.2 Rigging

DJPOWER recommends using the following general guidelines when mounting this product.

- Before deciding on a location for the product, make sure there is easy access to the product for maintenance and programming purposes.
- Make sure that the structure or surface onto which you are mounting the product can support the product's weight (see the Technical Specifications).
- When mounting the product on the floor, make sure that the product and cables are away from people and vehicles.
- When mounting the product overhead, always use a safety cable. Mount the product securely to a rigging point, whether an elevated platform or a truss.



# 5 OPERATION

## 5.1 Preparing for Operation

To prepare the H-22V for operation, perform the following steps.:

- After checking that all the parts are intact and complete, position the machine on flat.
- Refill the PRO-V fluid for machine, damage caused by the use of other fluid is not covered by the warranty
- Make sure the plastic hose entering the H-22V from the fluid tank cap is not bent or kinked.
- Connect the machine to the appropriate power socket. H-22V has main power supply and auxiliary power supply. The main power supply and auxiliary power supply must be connected to the power socket at the same time for the machine to work properly.
- Turn on the machine, and "Heating Up" shows on the display during the heating-up process. After approx. 15 minutes, the display changes to "Ready to Fog" when the machine is ready to output.

## 5.2 On-device Control Panel

To access the control panel functions, use the four buttons located underneath the LCD display.

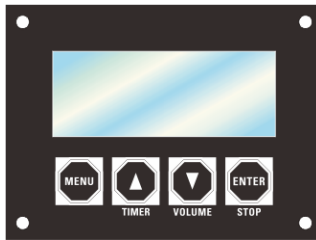

Button	Function
<MENU>	Switch menu pages to select a function
<TIMER>	Increases the numeric value of current function Triggers Timer output mode
<VOLUME>	Decreases the numeric value of current function Triggers Manual output mode.
<STOP>	Save settings STOP turns the fog output off

## 5.3 On-device Control Mode & Operation

### 5.3.1 Programming

- Refer to the Menu Map to understand the menu options. The menu map shows the main level and a variable number of programming levels for each option.

- To go to the desired main level, press <MENU> repeatedly until the option shows on the display. This will take you to the first programming level for that option.
- To select an option or value within the current programming level, press <TIMER> or <VOLUME> until the option shows on the display. If there is another programming level, you will see that first option, or you will see the selected value.
- Press <MENU> repeatedly to switch menu pages.
- Press <STOP> to go back to Standby Page.

### 5.3.2 Menu Map

	Display	Description	Parameter Range
<b>Welcome Pages</b>	TOPCAT H-22V Version V1	Software version	
<b>Preparing Pages</b>	Heating up 80% TOPCAT	The machine is heating up	
<b>Standby Page</b>	Ready to fog TOPCAT	Finished heating up, ready to work.	
	Timer Interval 600 S	Set interval output of TIMER mode	5-600 S
	Timer duration 10 S	Set duration output of TIMER mode	1-10 S
<p><b>Press "TIMER", the above pages will loop display. The time is base on the value of current setting. Press "VOLUME", the machine start smoking.</b></p>			
<b>Setting pages</b>	LED set close	Set led color	close,red, orange,yellow, green,cyan,blue, purple,white,auto color
	Upside mode down ON	After open hang upside down mode, the time of output is 4s	ON/OFF
	DMX Address 1	Press "▲" or "▼" to select DMX starting address	1-512
	RDM-UID 512D00040000	RDM_UID	

Auto Run Last Settings YES	Press "▲" or "▼" to set if the machine will automatically run previous setting when power on again	YES/NO
Auto black out Screen ON	Auto black out screen switch After turning on the auto black out function, the machine will auto black out the screen after 10 seconds without any button operation. Press any button to wake it up. At the same time, DMX control is not affected by screen off.	ON/OFF
Language English	Press "▲" or "▼" to select the language and save by ENTER	English/Chinese

## 5.4 DMX Mode & Operation DMX

The Machine H-22V works with a DMX controller.

- Connect the product to a suitable power outlet. H-22V has main power supply and auxiliary power supply. The main power supply and auxiliary power supply must be connected to the power socket at the same time for the machine to work properly.
- Turn the product on.
- Connect a DMX cable from the DMX output of the DMX controller to the DMX input socket on the product.

### 5.4.1 Starting Address

When selecting a starting DMX address, always consider the number of DMX channels. If you choose a starting address that is too high, you could restrict the access to some of the product's channels.



**DJPOWER® H-22V DMX set the starting address in the 001 - 512 DMX range and uses 9 DMX channels, which defines the highest configurable address to 503 to have all channels controllable.**



**Connect a DMX cable from the DMX output of the DMX controller to the DMX input socket on the product, or press repeatedly "MENU" button until the LCD shows "DMX Address". Press "▲" or "▼" to set desired DMX starting address.**

### 5.4.2 DMX Mode Menu Map

- When the machine connects to DMX, the display will always show DMX starting address, and you can set or change it at any time.



### 5.4.3 DMX Channel Assignments and Values DMX

#### 9 Channels

Channel	Function	Value	Description
1	Fog	000 - 127	Off
		128 - 255	On
2	LED Red	000 - 010	Off
		011 - 255	Dim to bright
3	LED Green	000 - 010	Off
		011 - 255	Dim to bright
4	LED Blue	000 - 010	Off
		011 - 255	Dim to bright
5	LED mix color	000 - 010	Off
		011 - 255	LED mix color
6	LED Auto color	000 - 010	Off
		011 - 255	Dim to bright
7	Strobe	000 - 010	Off
		011 - 255	Slow to fast
8	Dimmer	000 - 010	Off
		011 - 255	Slow to fast
9	Safety channel	000 - 049	DMX Invalid operation
		050 - 200	DMX valid operation
		201 - 255	DMX Invalid operation

### 5.4.4 RDM function

"RDM-UID" is the only UID code for H-22V. RDM allows two way communication between a controller and the unit. H-22V support 3 kinds of sensor information as below

#### H-22V support 3 kinds of sensor information as below:

Sensor	Function	Value	Description
1	Heating status	0	Heating
		1	Heating finished
2	NO-fluid status	0	Enough fluid
		1	No enough fluid
3	Pressure status	0	Pressure problem
		1	Pressure normal

### 5.4.5 Automatically turn off the screen

After turning on the automatic screen off function, the machine will automatically turn off the screen after 10 seconds without any button operation. Press any button to wake it up. At the same time, DMX control is not affected by screen off.

### 5.4.6 Upside down mode

Turning on the mode of hang upside down, the machine is in upside down state. The output time is auto shortened 4s, avoid hanging the machine upside down and squirt fluid.

## 6 TECHNICAL INFORMATION

### 6.1 Expected LED Lifespan

LEDs gradually decline in brightness over time, primarily due to heat. Packaged in clusters, LEDs exhibit higher operating temperatures than in ideal, single-LED conditions. For this reason, using clustered LEDs at their fullest intensity significantly reduces the LEDs' lifespan. Under normal conditions, this lifespan can be 40,000 to 50,000 hours. If extending this lifespan is vital, lower the operating temperature by improving the ventilation around the product and reducing the ambient temperature to an optimal operating range. In addition, limiting the overall projection intensity may also help to extend the LEDs' lifespan.

### 6.2 Maintenance

Do not allow the H-22V to become clogged. Dust build-up reduces light output performance and can cause overheating. This can lead to reduced light source life and increased mechanical wear. After every 40 hours of continuous operation, use a detergent composed of 35% vinegar and 65% distilled water through the system and spray 10-15 times after heat to prevent the accumulation of particulate matter in the heating element.

The recommended cleaning procedure is as follows.:

- 1) Unplug the product from power.
- 2) Empty all fluid from the machine.
- 3) Add cleaning solution to the tank.
- 4) Connect the product to power and allow it to warm up.
- 5) Run the product in a well-ventilated area until the tank is empty. Do not allow the pump to run dry.
- 6) Refill with fog fluid to continue using the H-22V. Run the machine briefly to clear any cleaning solution from the pump and heater.
- 7) Excessive dust, fluid residue and dirt will degrade performance and cause overheating. Remove dust from air vents with air compressor, vacuum or soft brush. The casing could be cleaned by the damp cloth.



**Test-run your DJPOWER® H-22V on a monthly basis to achieve the best performance.**

### 6.3 Machine Storage

Before storing the machine, clean it as described in the cleaning procedure above; however, only follow steps 1 through 5. Do not refill the tank with fog fluid if storing the machine. Cleaning the system prior to storage will help prevent any particles from condensing inside the pump or heater while not in use.

### 6.4 Minor failure

<b>Error code</b>	<b>Error</b>	<b>Potential Cause</b>	<b>Solution</b>
<b>E1</b>	Inflating problem	No-fluid in tank	Refill the fluid
		Fluid pump problem	Contact dealer for Service
<b>E3</b>	Pressure sensor problem	Pressure sensor problem	Contact dealer for Service
<b>E4</b>	Voltage problem	APS not connected to power outlet	APS connected to power outlet



